

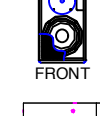

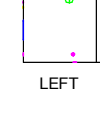
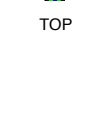

Bury The Dead

Sound Key

Directed by Joe Calarco
Sound Design by Michael Rasbury

-  -EAW JFX200
-  -EAW JF100
-  -EAW MK5364
-  -EAW JF60z
-  -EV Force IE Sub
-  -8 CHANNEL SNAKE
-  -CROWN PCC-160
-  -AT 808G Podium Mic

MODIFIED 10/22/08

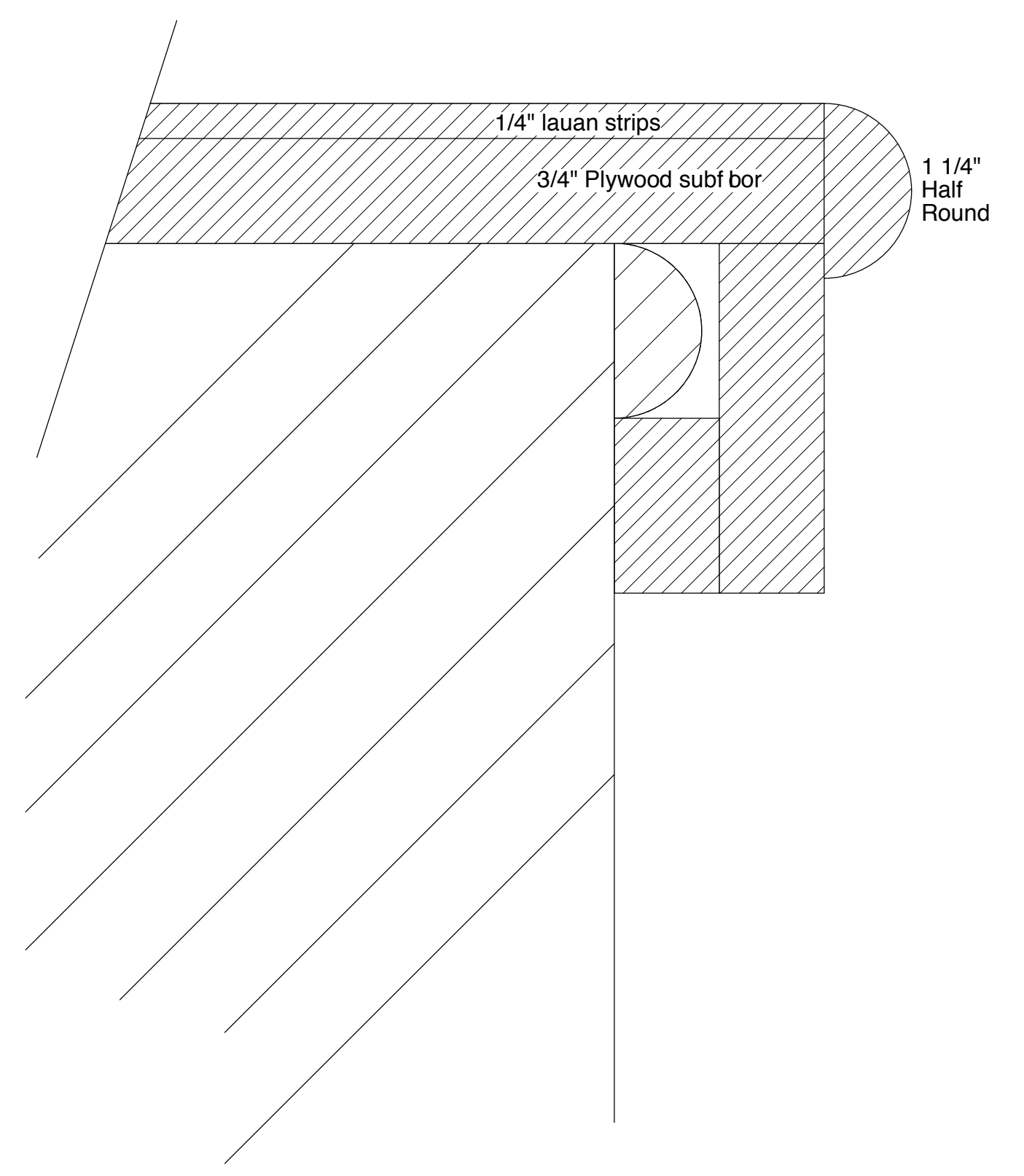
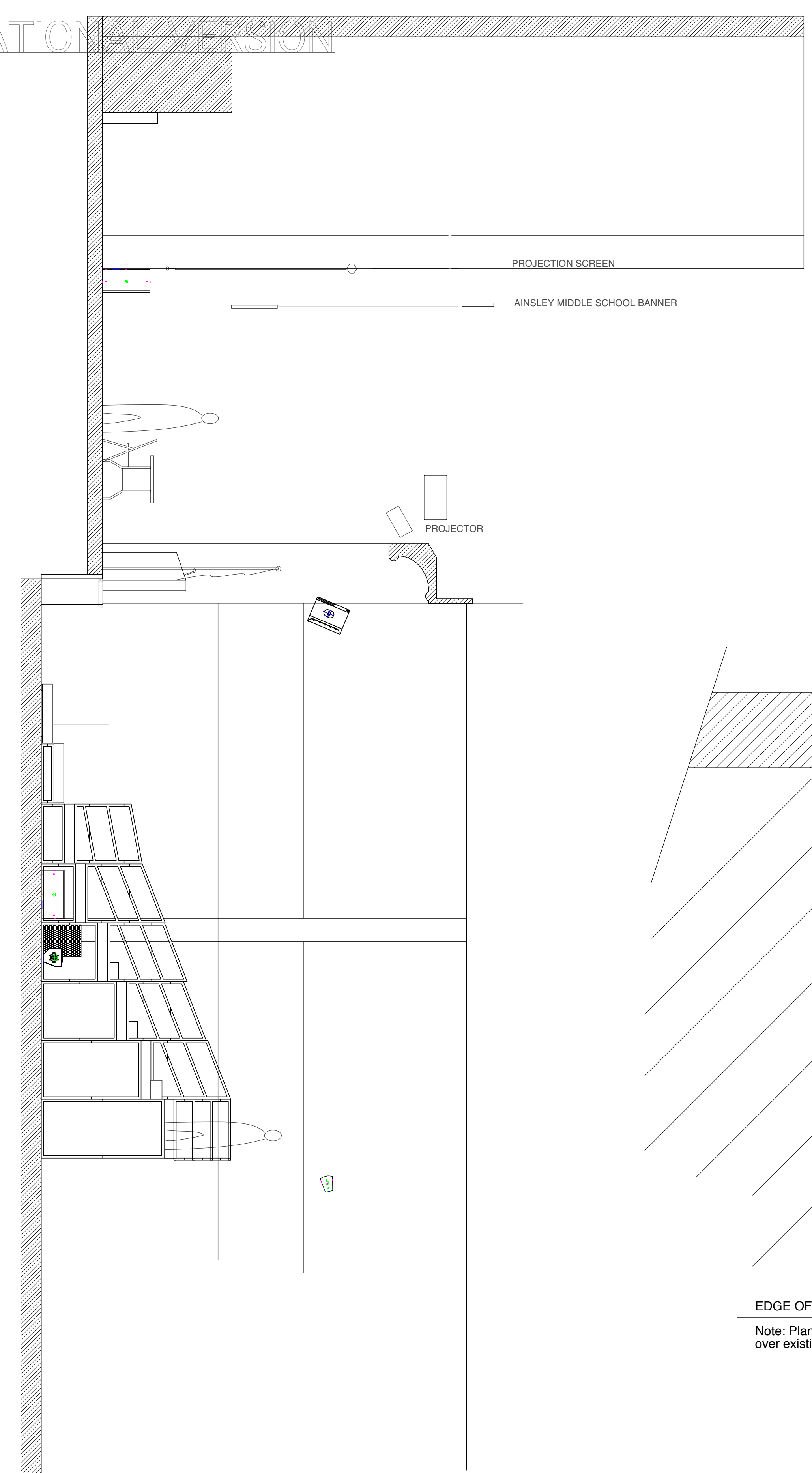
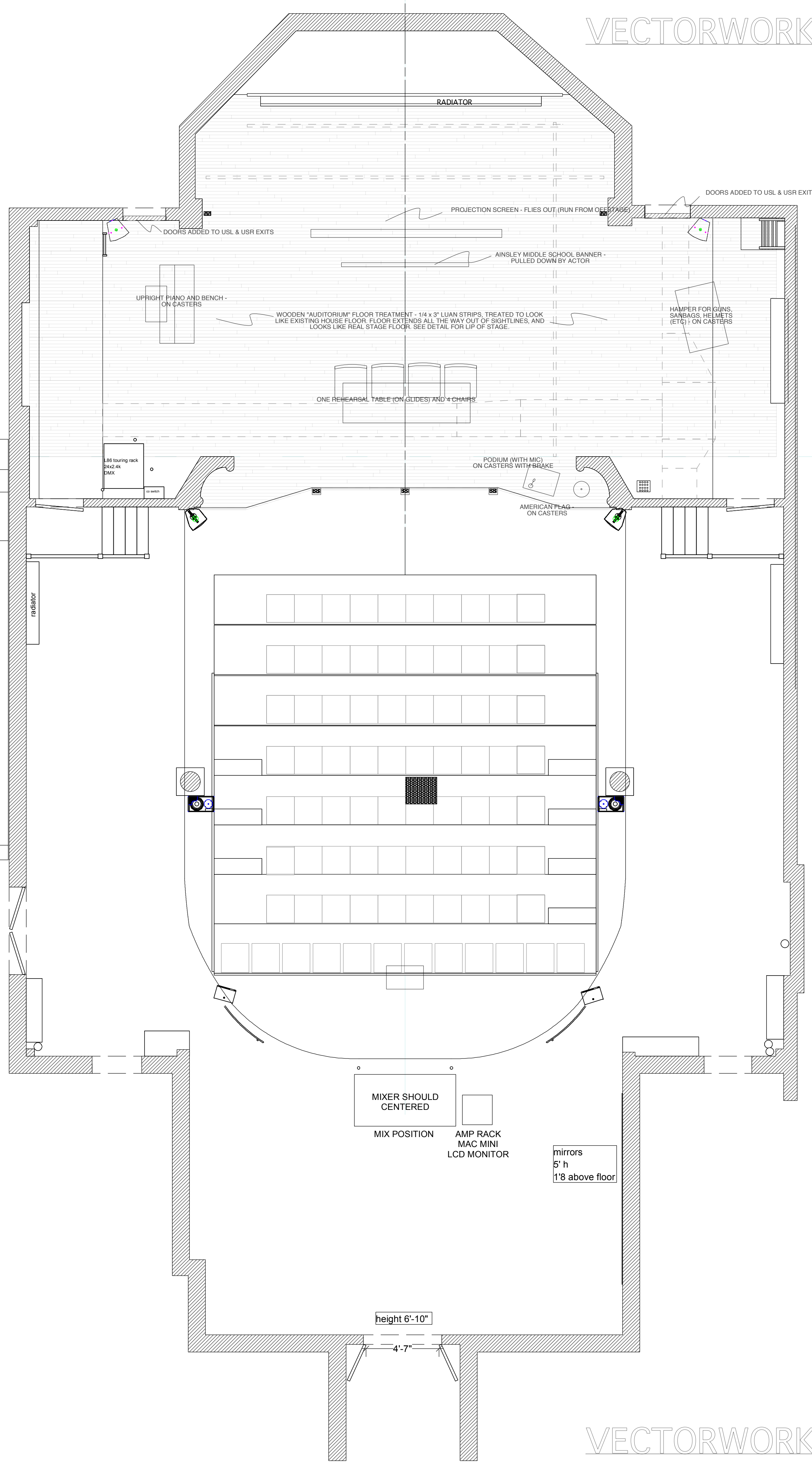

MIXER SHOULD CENTERED
MIX POSITION
AMP RACK
MAC MINI
LCD MONITOR

mirrors
5' h
1'8" above floor

height 6'-10"

4'-7"

TRANSPORT GROUP
BURY THE DEAD by Irwin Shaw
Directed by Joe Calarco Set Design by Sandra Goldmark
The Connelly Theatre Preliminary Plan and Section September 15, 2008
Scale: 1/4" = 1' - 0"